

PMT for Scintillation Counting and High Energy Physics 52 mm (2 Inch) Diameter, 122 mm Length, 8-stage, Head-on Type

SPECIFICATIONS

GENERAL

Parameter		Description/Value	Unit
Spectral Response		300 to 650	nm
Wavelength of Maximum Response		420	nm
Photocathode	Material	Bialkali	—
	Minimum Effective Area	46	mm dia.
Window Material		Borosilicate glass	—
Dynode	Structure	Linear focused	—
	Material	Bialkali	—
	Number of Stages	8	—
Ambient Temperature		- 30 to + 50	°C

CHARACTERISTICS(at 25°C)

Parameter		Min.	Typ.	Max.	Unit
Cathode Sensitivity	Luminous(2856K)	20	50	—	μ A/lm
	Blue(CS-5-58 filter)	8	12	—	μ A/lm
Anode Sensitivity and Dark Current	Sensitivity	100			A/lm
	Voltage	—	2800	3000	V
	Dark Current	—	100	800	nA
High Temp. Plateau		—	—	—	V
Time Response	Anode Pulse Rise Time	—	0.9	—	ns
	Electron Transit Time	—	17	—	ns

NOTE: Characteristics are measured with the voltage distribution ratio shown below.

VOLTAGE DISTRIBUTION RATIO AND SUPPLY VOLTAGE

Electrodes	K	G	Dy1	Dy2	Dy3	Dy4	Dy5	Dy6	Acc	Dy7	Dy8	A
Ratio	1	1	1	1	1	1	1	1	1	1	1	1

Supply Voltage: 2800Vdc, K: Cathode, Dy: Dynode, A: Anode, G: Grid
Acc to be connected to Dy7

Subject to local technical requirements and regulations, availability of products included in this promotional material may vary. Please consult with our sales office.

Information furnished by BEIJING ENERGY is believed to be reliable. However, no responsibility is assumed for possible inaccuracies or omissions. Specifications are subject to change without notice. No patent rights are granted to any of the circuits described herein.

PHOTOMULTIPLIER TUBE GDB60

Figure 1: Typical Spectral Response

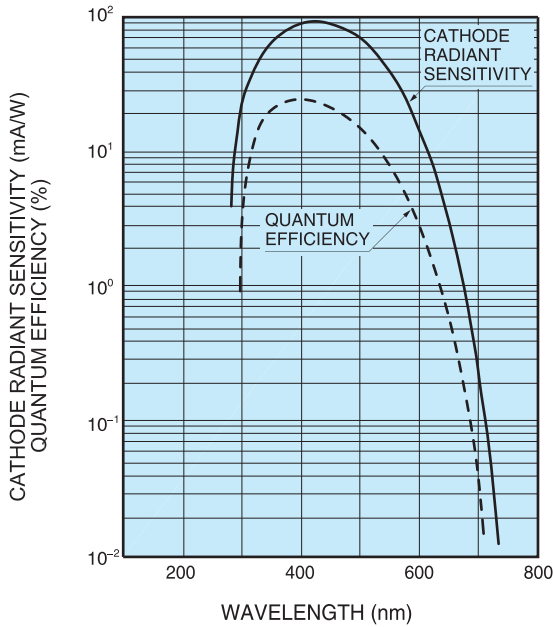

Figure 2: Typical Gain

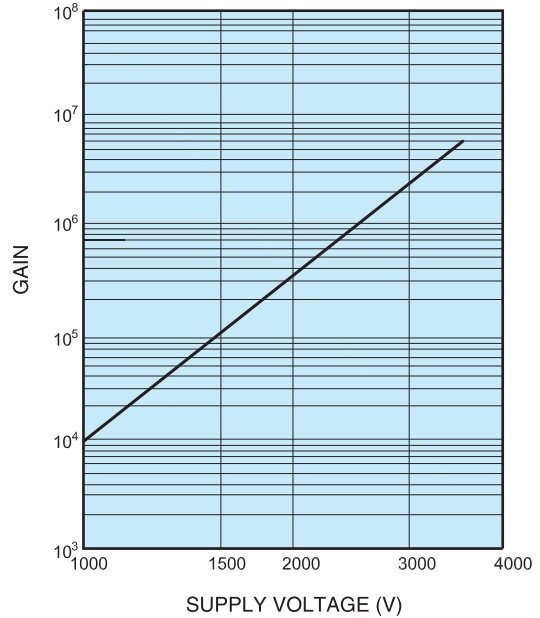
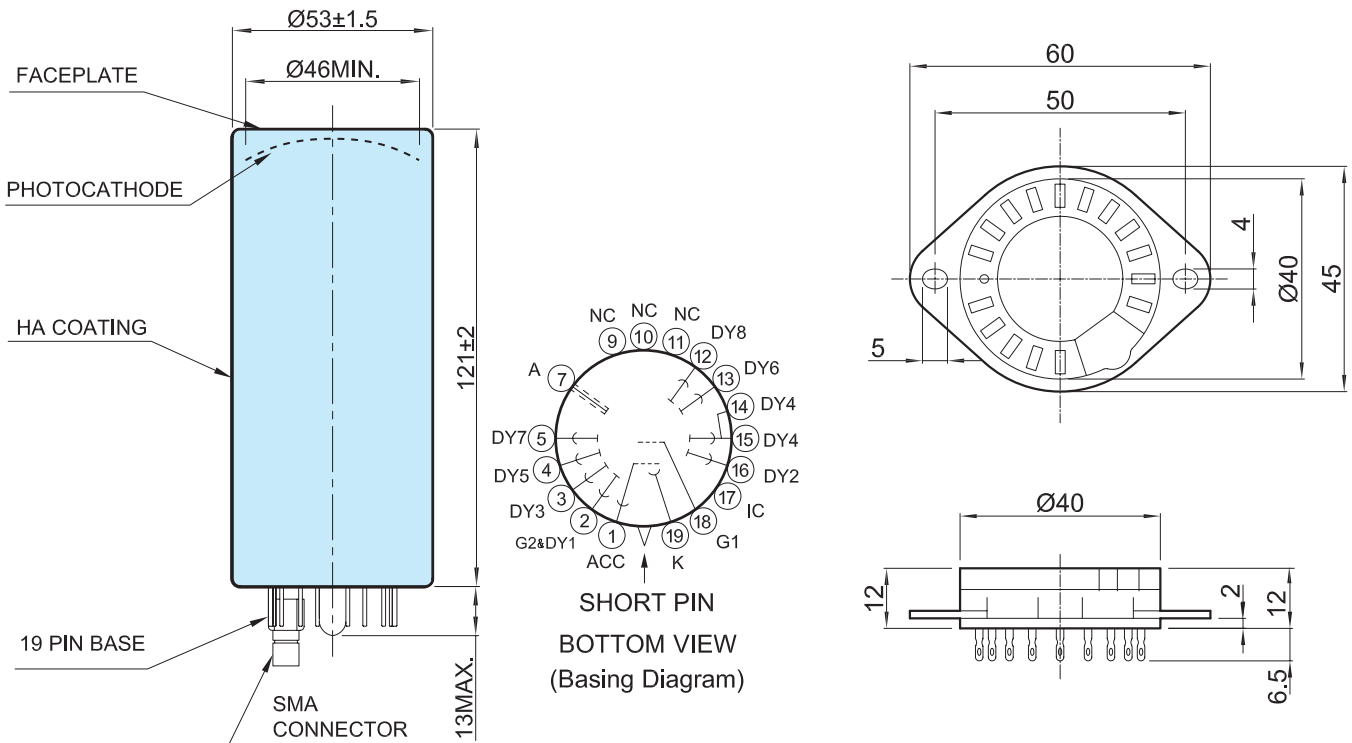

Figure 3: Dimensional Outline and Basing Diagram (Unit: mm)



BEIJING ENERGY

WEB SITE www.beijing-energy.com

Beijing Energy Science & Technology Co., Ltd.

ADD: 3F, Building C, BeiQiJia Industry Base, Changping District, Beijing, China, 102209

TEL:+86-10-6975 1218 / +8613911739991

FAX:+86-10-6975 1261

E-mail: Beijing_Energy@163.com